

4103 COMPACT 24V DC IONIZING STATIC BAR



Static Clean static control equipment has been designed to give you many years of productive service. However, the science of static control has unique rules which must be followed to allow the equipment to give a good return on your investment. Please read the following operating and maintenance instructions carefully.

Contents	Page
1 Introduction	4
2 Safety	6
3 Positioning and Installation	7
4 Electrical Connections	9
5 Monitoring: LED and Remote	12
6 Commissioning and Operation	13
7 Maintenance	13
8 Troubleshooting	14
9 Accessories	15
10 Appendix I: Technical Specification	17
11 Appendix II: Remote Interface and Wiring Examples	18

1. Introduction

The 4103 Static Eliminator is one of the range of high performance DC static eliminators from Static Clean International. These products are used by leading manufacturers throughout the world to increase safety and productivity.

Before you install the Bar, please follow the installation instructions carefully for maximum benefit.

1.1. Features and Benefits

The Static Clean 4103 Static Eliminator Bar is designed to neutralize electrostatically charged surfaces.

Powered by 24 V DC, it features integrated high voltage supplies meaning that no high voltage cabling is required.



The status of the 4103 Bar, including need for cleaning, is indicated by the LED on the endcap. Duplicate outputs enable integration with control system/PLC.

The 24 V DC power supply and remote monitoring connections are made via an M8 4 pin connector. An external AC Adapter Power Supply can be ordered if 24 V DC is not available.

Mounting onto the machine is with M6x40 T-bolt w/ flange nut which slides into the slot in the Bar

1.2. Checking on Delivered Equipment

Before starting the installation please check that the 4103 Bar has not been damaged in transit. If the packaging material is damaged please report this immediately to the vendor.

Check that the additional items are present with the Bar:



Mounting

Bars upto 1000mm (39") in length are supplied with two mounting blocks. Mounting blocks are supplied for each additional 500 mm (19.68") or part thereof. For example:

850 mm (33.46"): 2 mounting blocks

1300 mm (51.2"): 3 mounting blocks

1800 mm (70.86"): 4 mounting blocks

It is important to use all the mounting blocks supplied.



Power Supply Cable

If ordered, a 24 V power supply cable with an M8 x 4 pin connector will be supplied.

See Section 9 for details of cables and other accessories.



IMPORTANT

DO NOT USE standard 'computer style' PSUs. These do not have secondary earths and risk operator shocks and damage to the 4103 Bar. Only use the Static Clean external Power Supply Unit (P/N: 4203-31101).



2. Safety

The Static Clean 4103 Static Eliminator Bar has been designed in accordance with the safety requirements of EN 62368-1:2014. This IEC-derived standard is harmonized under the EU Low Voltage Directive and recognised by UL.

- The emitter pins are resistively coupled to the high voltage supplies. The emitters are a Class 1 electrical energy source, as defined in EN 62368 -1:2014. Contact with the emitters is not painful and will not result in electrically-caused injury, but may cause a detectable sensation due to the small current which will flow.
- The emitter pins of the Bar are necessarily sharp. The emitter pins are a Class 2 mechanical energy source, as defined in EN 62368 -1:2014. Contact with them may be painful, but will not cause an injury requiring emergency medical attention. Take care when handling the Bar.
- Installation and maintenance work on the Bar must only be carried out by suitably qualified personnel.
- The negative pole of the 24 V DC supply provided to the Bar must be permanently earthed.
- Adequate installation earth / ground is required to ensure safe and proper operation.
- Do not connect or disconnect the M8 cable from the Bar whilst it is powered.
- A small amount of ozone will be produced as part of the ionization process. When installed correctly the level of concentration of ozone is less than 0.1 ppm and is within internationally accepted limits.

3. Positioning and Installation

Please note that long lengths of the 4103 Bar need careful handling during installation to avoid damage. Bars over 2 m (78") in length must be handled by two people.

3.1. Locating the Bar

- The most effective Bar installation location is at or immediately before the area where static is causing a problem, but remember that static can be re-generated by subsequent passage over rollers or through another process.
- The 4103 Bar should be mounted in a clean, dry and oil-free location.
- A static meter such as the Static Clean DZ4 is useful in determining the best location for the Bar.

3.2. Positioning the Bar

- Except on a winding reel of material, the material to be neutralized should be in free air and not touching another surface as it passes the Bar.
- It is not possible to neutralize static where the material is touching another surface or roller.
- Position the Bar such that no earthed metal parts are closer to the Bar than the material to be neutralized - earthed objects can attract ions away from the target reducing the neutralization power and causing an ion imbalance.
- The distance between the Bar and material to be neutralized is 20-150mm (0.75"-5.90").
The best distance is 20-50mm (0.75"-2.00").

3.3. Mounting the Bar

- Use all of the mounting blocks provided for mounting the Bar. These slide into the slot in the base of the Bar.
- When mounting the Bar, the mounting blocks slides should be distributed evenly along the length of the Bar. Do not allow more than 800mm (31.50") of unsupported Bar between mounting blocks.

3.4. Summary

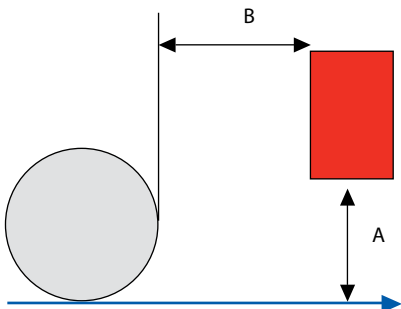
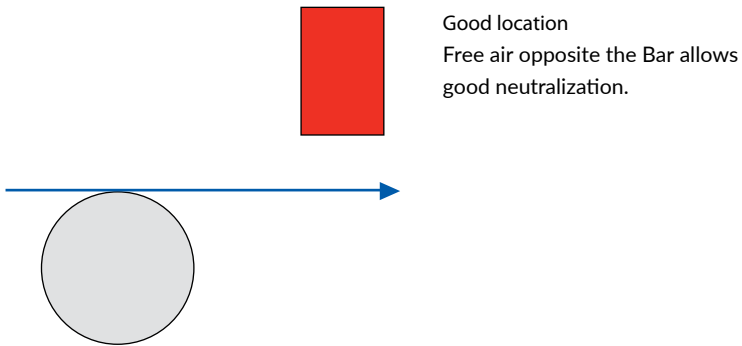
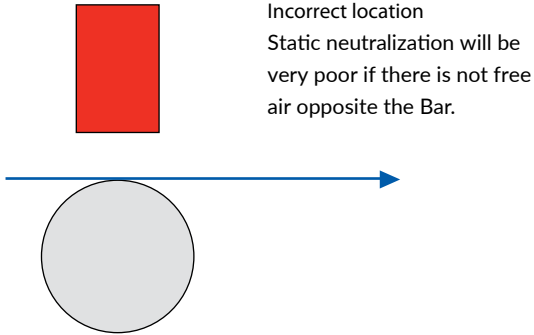

- A: 20-150mm (0.75"-5.90")
(20-50mm (0.75"-2.00") for best performance).
- B: Larger than A to avoid ion loss to rollers or parts of machine.

4. Electrical Connections

WARNING: The 0 V (negative) output of the 24 V DC supply to the 4103 Bar must be earthed. If this is not done, the Bar and Power Supply will be damaged and all warranties will be voided.



IMPORTANT: The electrical specifications and signalling scheme of the remote monitoring interface differ from those of other Static Clean 24V static eliminator Bars. (4203). Please read these instructions carefully before installing the Bar.



All electrical connections to the Bar are made via the M8 4-pole male connector on the endcap of the Bar.

If using the Static Clean external Power Supply Unit (p/n 4203-31101), simply connect the M8 cable from the Power Supply to the Bar and ensure that the supplementary ground wire is connected to installation protective earth before connecting mains power.

If using a separate 24 V Power Supply and Cable (e.g. as part of a machine control cabinet installation), follow the instructions on page 10 for connecting the Bar.

4.1. M8 Pin Assignments

The M8 connector pin numbering scheme is shown below.

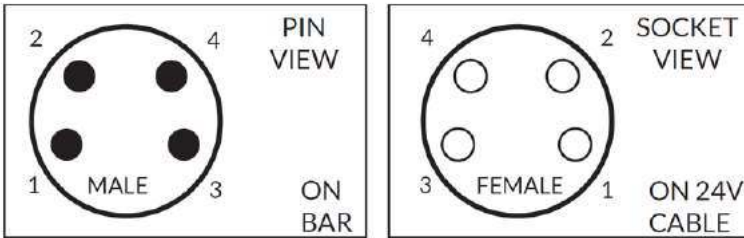

The pin assignment and typical wire colours are given in the table below. This refers to cables supplied by Static Clean. Other cables may have different colour schemes.

Pin	Wire Colour	Function	Details
1	Brown	+24 V	21 – 27 V operating range, 0.5 A maximum current.
2	White	OK signal	+24 V nominal output voltage, 3 k Ω output impedance in active state. Low impedance connection to 0 V in inactive state. See Appendix II for details.
2	Blue	0 V + GND	0 V must be connected to ground.
4	Black	ATTENTION signal	+24 V nominal output voltage, 3 k Ω output impedance in active state. Low impedance connection to 0 V in inactive state. See Appendix II for details.

4.2. Power Supply Connections

The diagram below shows the power supply connection requirements when using the 24 V DC power supply on the customer's machinery.

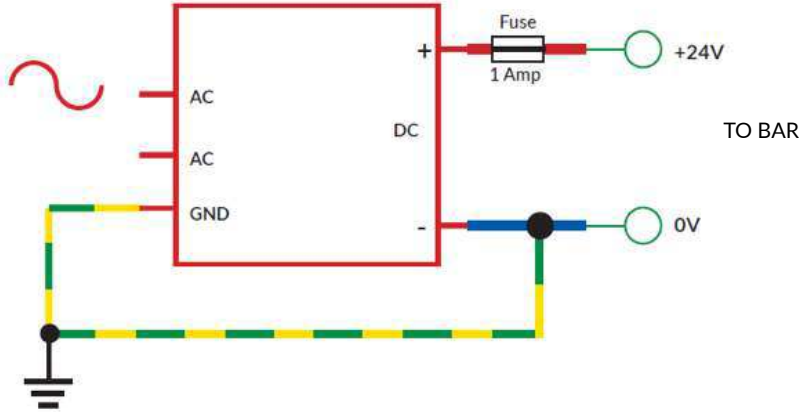

The 24 V supply connection (Pin 1, brown wire) must be fitted with a 1 A fuse. It is recommended that a type 'T' or 'gG' fuse is used.

The 0 V supply connection must be connected to installation protective earth (PE). This connection should be made at the power supply output terminal if possible. There is no additional grounding connection to the Bar – it is essential that this connection is made externally.

WARNING: If the 0 V output of the DC power supply is not grounded, there is a risk of the operator receiving an electric shock from the M8 connector on the Bar.

CAUTION: If the 0 V output of the DC power supply is not grounded, damage may occur to the power supply and/or the Bar.

CAUTION: If the 0 V output of the DC power supply is not grounded the residual voltage (balance) level of the Bar cannot be guaranteed.



5. Monitoring: LED and Remote

The LED on the endcap of the Bar indicates its status as follows:

LED Indication	Bar status	Ionization
Green	OK.	Active
Green/red flashing	Cleaning/attention required.	Active
Red	Overload, hardware fault, supply voltage out of range.	Inactive
Not illuminated	Bar not powered.	Inactive

The 4103 Bar is equipped with a remote monitoring interface which allows the operating status of the Bar to be fed into a PLC system or checked remotely.

Please see Appendix II for wiring instructions and examples for the remote monitoring interface.

Please read these instructions carefully before installing the Bar, because the electrical specifications and signalling scheme of the remote monitoring interface differ from those of other Static Clean 24 V Static Eliminator Bar (4203).



6. Commissioning and Operation

Before turning the Bar on for the first time, check:

- The positioning and mounting of the Bar is in accordance with the instructions given in section 3 of this document.
- The electrical installation of the Bar has been completed in accordance with the instructions given in section 4 of this document. In particular, ensure that the 0 V output of the 24 V supply is connected to the installation protective earth.
- If using the external AC-DC power adapter, ensure that the supplementary grounding wire is connected to the installation protective earth.
- Any operators who will work in close proximity to the Bar are aware of its presence and familiar with its operation.

7. Maintenance

WARNING: Always disconnect power before working on the Bar.

Cleaning is the only maintenance required. Dirt around the emitters will reduce ionization effectiveness and result in unsatisfactory static neutralization performance.

The frequency of cleaning will depend on the process and the environment in which the Bar is installed. The Bar should be cleaned when 'attention required' is indicated by the endcap LED and/or remote monitoring interface.

To ensure best performance, the Bar should be visually inspected on a regular basis and cleaned whenever convenient.

A cleaning kit is available from Static Clean, part number 4203-81220. This is the ideal solution for regular Bar cleaning. Alternatively a toothbrush or soft nailbrush can be used. Do not use a wire brush as this may cause damage to the Bar.

Alternative cleaning materials are warm soapy water, or isopropyl alcohol (IPA). The Bar must be dry before the power is switched back on.



8. Troubleshooting

In the event of problems with the Bar, please use the following checks.

Symptom	Cause(s)	Solution(s)
No LED	Bar not powered.	<ul style="list-style-type: none"> • Check power supply and connections. • Check fuse. • Check supply cable for damage.
Red LED	Power supply voltage outside of specified range.	<ul style="list-style-type: none"> • Check and adjust power supply voltage. • Ensure appropriate power supply cable used. • Ensure power supply not overloaded.
	HV supplies overloaded.	<ul style="list-style-type: none"> • Check Bar installation. • Move Bar further from earthed metal objects. • Check Bar for damage.
	Internal fault.	<ul style="list-style-type: none"> • Contact supplier.
Red/Green LED	Emitters need cleaning.	<ul style="list-style-type: none"> • Power off and clean Bar.
	Bar installed too close to machine parts.	<ul style="list-style-type: none"> • Check Bar installation. • Move Bar further from metal parts.
Poor Ionization/ Neutralization Performance	Emitters need cleaning.	<ul style="list-style-type: none"> • Clean Bar.
	Emitters worn.	<ul style="list-style-type: none"> • Check emitters for excessive wear. • Replace Bar.
	Bar installed too close to machine parts.	<ul style="list-style-type: none"> • Review installation, move Bar away from machine parts if possible.
	Bar installed too far from material to be neutralized.	<ul style="list-style-type: none"> • Review installation, move Bar closer to material if possible.
	Bar installed opposite roller/machine parts.	<ul style="list-style-type: none"> • Review installation, move Bar opposite material in free air if possible.

9. Accessories

A range of accessories to assist with installation and maintenance of the Bar are available from Static Clean International. Please contact your local distributor to enquire regarding pricing and delivery of these items.

Item Picture	Description	Part No.
	3 m cable M8 female, Bare ends. Straight socket.	4203-80892
	5 m cable M8 female, Bare ends. Straight socket.	4203-80930
	7.5 m cable M8 female, Bare ends. Straight socket.	4203-80931
	10 m cable M8 female, Bare ends. Straight socket.	4203-80932
	3 m cable M8 female, Bare ends. 90° socket.	4203-80933
	5 m cable M8 female, Bare ends. 90° socket.	4203-80934

9. Accessories

Item Picture	Description	Part No.
	<p>7.5m cable M8 Female, Bare ends 90° socket.</p>	<p>4203-80935</p>
	<p>10m cable M8 Female, Bare ends 90° socket.</p>	<p>4203-80936</p>
	<p>External Universal Power Adapter w/ 1.2m (4ft) cable & M8 4-pin female connector</p>	<p>4203-31101</p>
	<p>M8 male to M8 female 4-pin extension cable for AC/DC power supply unit. (available in 2m lengths.)</p>	<p>4203-80937</p>
	<p>Additional mounting set (includes M6x40 T-bolt & flange-nut)</p>	<p>4103-30248</p>
	<p>Static Clean Ionizer Cleaning kit containing:</p> <ul style="list-style-type: none"> • 500 ml of Cleaning Fluid. • Soft bristle hand brush. • Instructions for use. 	<p>4203-81220</p>

10. Appendix I: Technical Specification

Power Supply

Input voltage:	24 V DC nominal, 21-27 V operating range. 0 V earthed.
Input current:	0.5 A max.
Maximum input power:	12 W.
Input connector:	M8, 4-pole, male.

Output

Output voltage:	±7.5 kV ±5%
Output frequency:	50 Hz
Emitter Material:	Tungsten.
Emitter Touch Current:	80 µA max. per emitter.

Monitoring

Endcap LED status indication:	Green flashing: - OK, Bar operating normally. Red/green flashing: attention required. Red: supply voltage out of range or internal fault.
-------------------------------	---

Remote Monitor

Signalling outputs:	'OK' and 'Attention'.
Signalling levels:	24 V output, 3 kΩ output impedance.
Output current:	Sourcing (+24 V): 8 mA Sinking (0 V): 20 mA Limited to 50 mA max. (output low) by internal protection.

PLC compatibility

Remote monitor states:	Compatible with IEC 61131-2 'Type 3' PLC inputs. Bar OK, Attention Required, Fault, Bar not powered.
------------------------	---

Protection

Internal protection:	Under-/over-voltage lockout, surge protection, reverse supply polarity protection. HV supplies protected against overload. Signalling outputs protected against short-circuiting.
----------------------	---

Environmental Conditions

Ambient temperature:	14-131 °F.
Relative humidity:	Maximum 70%, non-condensing.
Ingress protection:	IP67. Bar will not be damaged by exposure to water, but will not function correctly if the emitters are bridged by moisture.

Mechanical

Dimensions:	20x32.5mm (0.78" x 1.27") Available in lengths from 250mm (9.84") to 4000mm (157.48") in 40mm (1.57") steps.
Length:	(157.48") in 40mm (1.57") steps.
Mass:	0.15 kg + 0.51 kg/m e.g. 1 m Bar: 0.66 kg
Materials:	FR-ABS, epoxy resin, tungsten emitters, steel fixings.
CE Marking	
U LVD (2014/35/EU):	EN 62368-1:2014
EU EMC (2014/30/EU)	Emissions: EN 61000-6-3:2007 Immunity: EN 61000-6-2:2005

11. Appendix II: Remote Interface and Wiring Examples

This section describes the functioning of the remote monitoring interface in more detail and provides wiring examples for common installation types.

11.1. Remote Signalling Scheme

The remote monitoring interface has two output signals, OK and ATTENTION. The signalling scheme is described in the following table:

Condition	Ionisation	OK (White, Pin 2)	Attention (Black, Pin 4)
Bar powered, all OK	ACTIVE (HV ON)	ACTIVE (24V)	ACTIVE (24V)
Bar powered, requires attention (e.g. cleaning)	ACTIVE (HV ON)	ACTIVE (24V)	INACTIVE (0V)
Overload, hardware fault, supply voltage out of range	INACTIVE (HV OFF)	INACTIVE (0V) Will sink current.	INACTIVE (0V) Will sink current.
Bar not powered	INACTIVE (HV OFF)	INACTIVE (0V) Will not sink current.	INACTIVE (0V) Will not sink current.

IMPORTANT: The OK output always directly indicates the ionization state of the Bar.

IMPORTANT: Because the outputs are implemented using an electronic switch rather than a relay, when the Bar is not powered, the outputs will not sink current.

11.2. Remote Interface Electrical Specifications

The OK and ATTENTION signals are designed to allow direct connection to PLC digital inputs conforming with IEC 61131-2 'Type 3' characteristics. The detailed specification of the remote signalling outputs is given in the table below.

Characteristic	Specification	Notes
High-level output voltage, open-circuit	VIN – 0.5 V	VIN is nominally 24 V. High-level output voltage depends on power supply voltage.
Output impedance, high-level	3 kΩ	Internal pull-up to VIN.
Maximum output current, high-level, VIN = 24 V (sourcing)	8 mA	Output shorted to 0 V.
Low-level output voltage, open-circuit	0 V	Connected internally to 0 V by low-impedance switching device.
Output impedance, low-level	<50 Ω	
Maximum output current, low-level (sinking)	20 mA	Protected by internal self-resetting fuse.
Maximum externally applied voltage	28 V	Signal output is also protected against transient over-voltage.

The simplified schematic diagram on page 20 shows the implementation of the remote signalling outputs.

The simplified schematic diagram below shows the implementation of the remote signalling outputs.

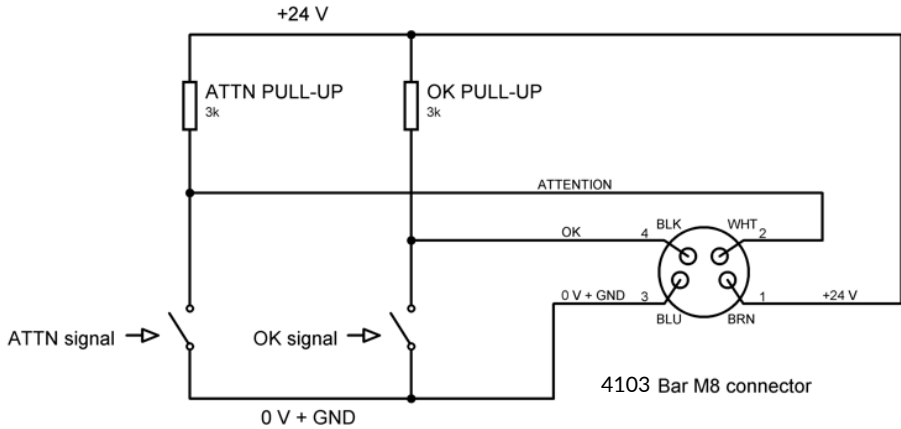

The switches in the diagram above are shown in the position corresponding to 'Bar powered, all OK'.

11.3. Interfacing with PLC systems

To interface the Bar with a PLC digital input conforming with IEC 61131-2 'Type 3' characteristics, simply connect the 'OK' and/or 'ATTENTION' outputs from the Bar to the PLC digital input module as shown below.

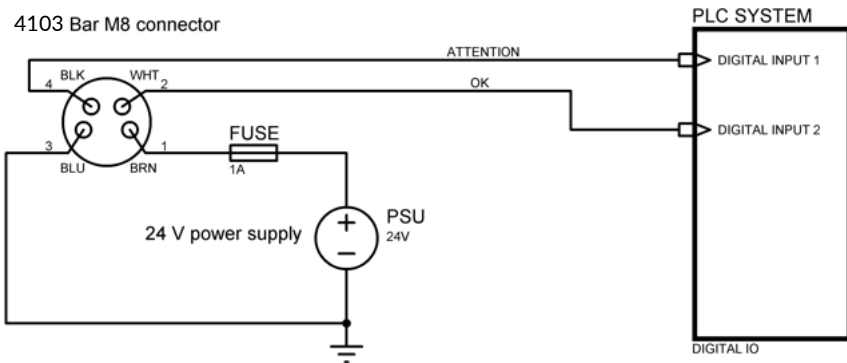

To interface the Bar with a PLC system having IEC 61131-2 'Type 1' or 'Type 2' input characteristics, fit an external 1 kΩ pull-up resistor to supply the current required by these input types, as shown below. These resistors should have a power rating of at least 1 W.

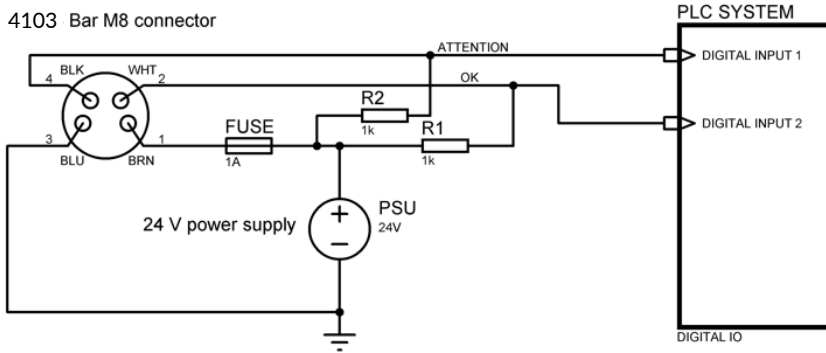

11.4. Powering the Bar directly from a PLC digital output

A typical 24 V, 0.5 A PLC output is capable of supplying the average current required by the Bar, and can be used to power the Bar directly.

It is possible that over-current trips may be experienced on PLC outputs due to the pulsing of the HV supplies in the Bar. This will depend on the characteristics of the PLC output module. In this case, use the PLC output to control a relay which switches the main 24 V supply to the Bar.

11.5. Connecting external indicators

Typical 24 V LED-based industrial indicators with rated current of 20 mA or less can be driven by the remote signalling outputs.

The recommended wiring scheme for external indicators is shown below. Note that the connections for the OK and ATTENTION signals are different.

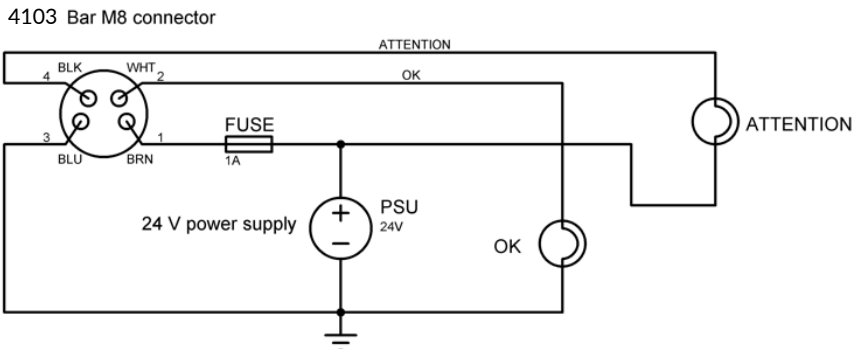

With this wiring scheme, the indicators will illuminate according to the table below.

Bar Status	OK Indicator	ATTENTION Indicator
Powered, all OK	ON	OFF
Attention required	ON	ON
Fault, overload, supply voltage out of range	OFF	ON
Bar not powered	OFF	OFF

IMPORTANT: Connecting indicators with higher current requirements to the Bar will not damage it, but it is unlikely that satisfactory brightness will be obtained.



11.6. Connecting external relays

To provide potential-free contacts or switch a higher voltage or current level, relays can be installed between the Bar and external control circuit.

External relays must be connected with the Bar output sinking current to energize the relay coil.

PLC interfacing relays with high-sensitivity 24 V DC coils should be used to interface with the Bar. Some examples are:

- Phoenix Contact PLC-RSC series.
- Finder 38 series.
- Wieland FLARE-24DC series.
- Omron G2RV series.

IMPORTANT: Relay coil drive current at 24 V should not exceed 20 mA.

IMPORTANT: External relays should be fitted with coil suppressors.



The recommended wiring scheme for external relays (using SPCO relays) is shown below.

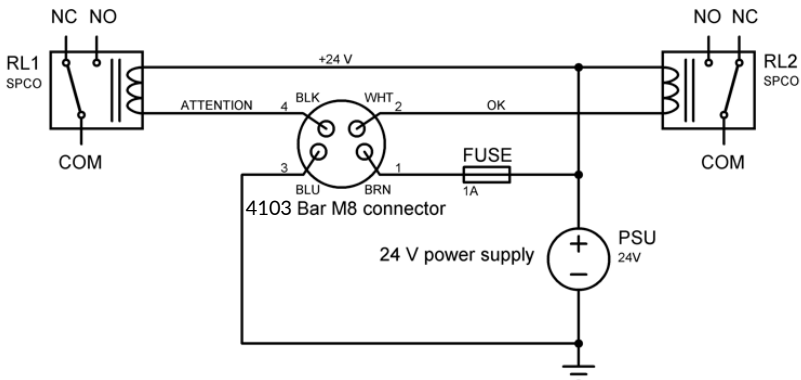

The relay contacts will be connected according to the following table.

Bar Status	OK Relay (RL2)	ATTN Relay (RL1)
Powered, all OK	OPEN (COM → NC)	OPEN (COM → NC)
Attention required	OPEN (COM → NC)	CLOSED (COM → NO)
Fault, overload, supply voltage out of range	CLOSED (COM → NO)	CLOSED (COM → NO)
Bar not powered	OPEN (COM → NC)	OPEN (COM → NC)

IMPORTANT: Due to the use of electronic switches within the Bar, it is not possible to determine remotely that the Bar is not powered when using external relays.



For more information about static and to view the full range
of our products, please visit www.staticclean.com



Static Clean International

267 Boston Rd. Suite #8 North Billerica, MA 01862
781-229-7799 P 781-229-4555 F www.staticclean.com